

10G SFP+ CWDM 40 DM Transceiver

MODEL: SFP+CWDM



PRODUCT FEATURES

- Hot-Pluggable SFP+ Footprint
- Duplex LC connector
- CWDM EML Transmitter from
- 1470nm to 1610nm, with step 20nm
- Power Dissipation < 1.5W
- Dispersion tolerance 800ps/nm
- Case Operation Temperature:
- Standard: 0°C to 70°C
- Compliant with SFF-8431 MSA
- Compliant with SFF-8432 MSA
- Compliant with SFF-8472 MSA

Applications:

- 10GBASE-ER/EW
- 10G fiber channel
- Other optical links

Absolute Maximum Ratings

Table 1- Absolute Maximum Ratings

Parameter	Symbol	Min.	Typical	Max.	Unit	Notes
Storage Temperature	Ts	-40	-	85	°C	
Supply Voltage	Vcc5	-0.5	-	4.0	V	
Operating Humidity	RH	-	-	+85	%	

Recommended Operating Conditions

Table 2- Recommended operating Conditions

Parameter	Symbol	Min.	Typical	Max.	Unit	Notes
Operating Case Temperature	Top	0	-	70	°C	
Power Supply Voltage	VCC	3.14	3.3	3.46	V	
Power Supply Current	ICC	-	-	450	mA	
Power Dissipation	PD	-	-	1.5	W	
Data Rate	BR	9.95		11.3	Gbps	

Electrical Characteristics

Table 3- Electrical Characteristics

Transmitter						
Parameter	Symbol	Unit	Min.	Typ.	Max.	Notes
Differential Data Input Amplitude	V _{in,p-p}	mVpp	180	-	700	
Input Differential impedance	Z _{in}	Ω	85	100	115	
Tx_Disable,P_Down/RST	V _{IL}	V	-0.3		0.8	
	V _{IH}	V	2.0	-	V _{cc} +0.3	
Receiver						
Differential Data Output Amplitude	V _{out,p-p}	mVpp	300		850	
Output Differential impedance	Z _{in}	Ω	80	100	120	
Output Rise Time,20%-80%	T _r	Ps	28			
Output Fall Time,20%-80%	T _f	Ps	28			
Rx_Los,Mod_NR,Interrupt	V _{oL}	V	0		0.4	
	V _{oH}	V	V _{cc} -0.5		V _{cc} +0.3	

Transmitter Performance

Table 4- optical TX Characteristics

Parameter	Symbol	Min.	Typical	Max.	Unit	Notes
Average Launch Optical Power	P _{out}	-2	-	+4	dBm	1
Extinction Ratio	ER	8.2	-	-	dB	2
Average Launch power of OFF TX	P _{off}	-	-	-30	dBm	1
Optical Wavelength	λ	λ _c -6.5	λ-	λ _c +6.5	nm	
Dispersion penalty@9.95/10.7Gpbs	DP1	-	-	2	dB	2
Dispersion penalty@11.1/11.3Gpbs	DP2	-	-	3	dB	3
Side Mode Suppression Ratio	SMSR	30	-	-	dB	

Receiver Performance

Table 5- optical RX Characteristics

Parameter	Symbol	Min.	Typical	Max.	Unit	Notes
Receiver Sensitivity @9.95Gpbs/10.7Gpbs	PIN_SENS1	-	-	-16	dBm	2
Receiver Sensitivity @11.1Gpbs/11.3Gpbs	PIN_SENS2	-	-	-14	dBm	3
Overload	PIN_OL	-7.0	-		dBm	3
Optical Center Wavelength	λ _c	1260	-	1600	nm	
Los Assert	LOSA	-28	-	-	dBm	
Los De-assert	LOSD	-	-	-18	dBm	
Los hysteresis	LOSH	0.5	-		dB	
Rx_LOS	High		2.0		V _{cc} +0.3	V
	Low		0		0.8	V

Note:

The optical power is launched into SMF.

Measured with a PRBS 231-1 test pattern @9.95Gpbs.

Measured with a PRBS 231-1 test pattern , @11.1Gpbs. BER≤10-12.

Recommended Host Board Power Supply Circuit

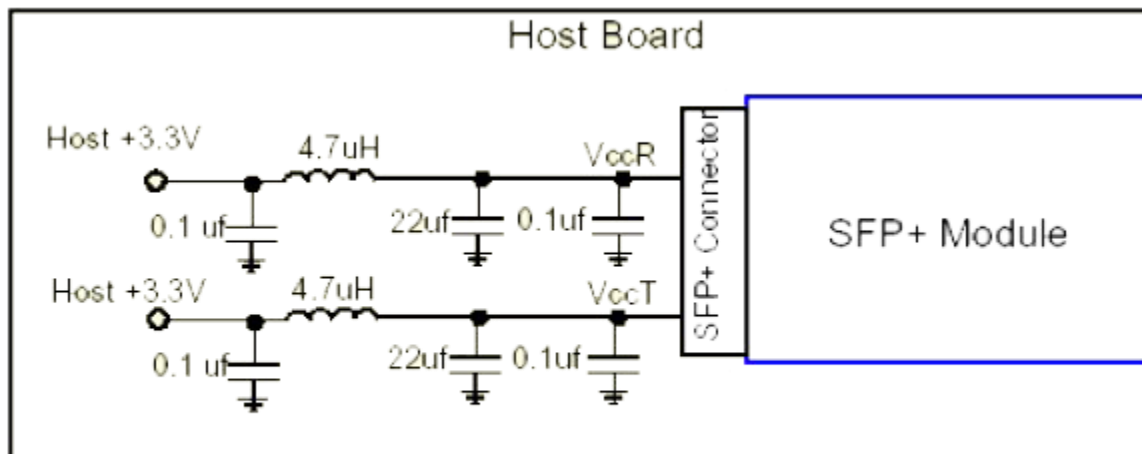

Figure 1, Recommended Host Board Power Supply Circuit

Recommended interface circuit

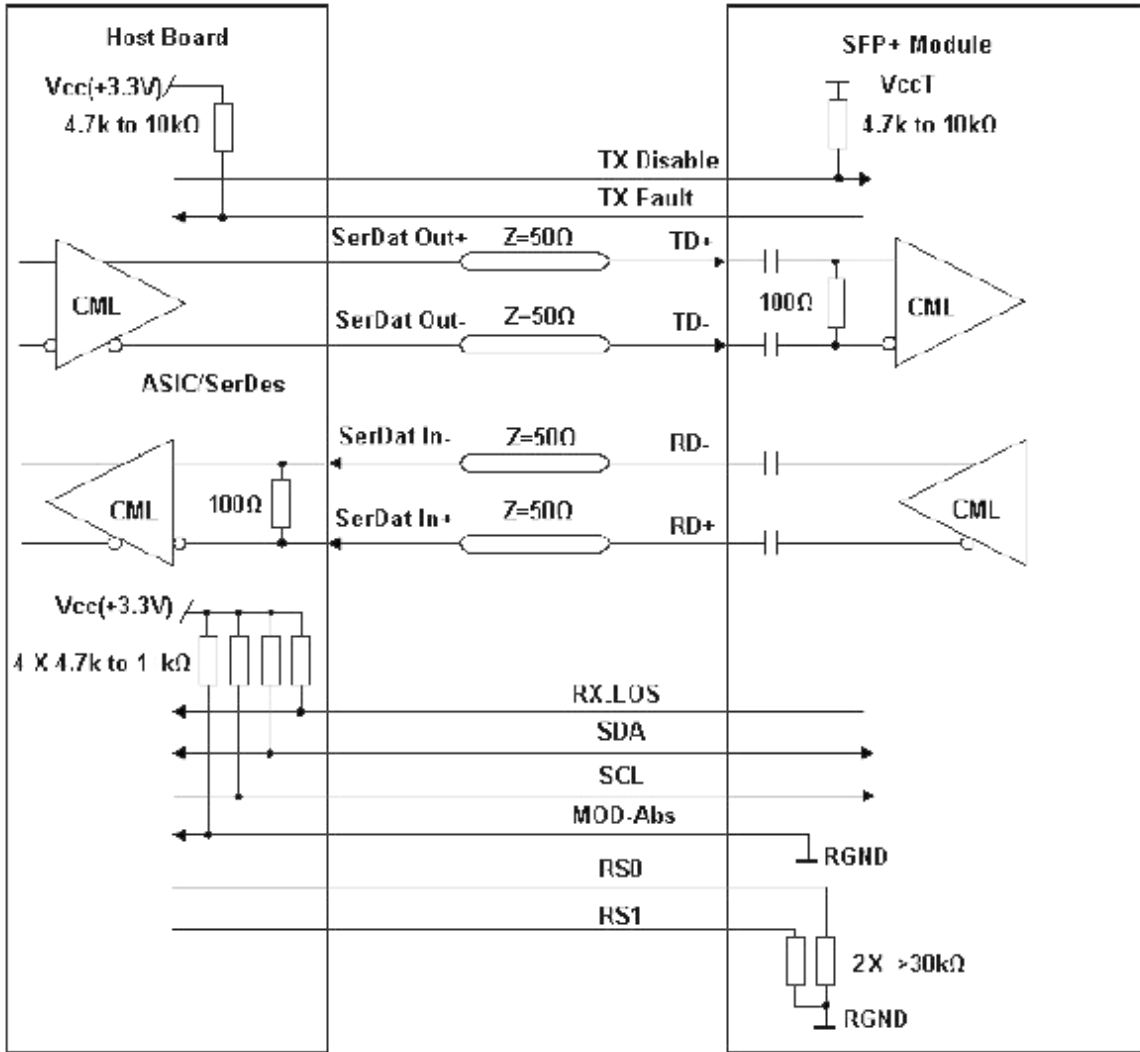

Figure 2, recommended interface circuit

Pins Arrangement

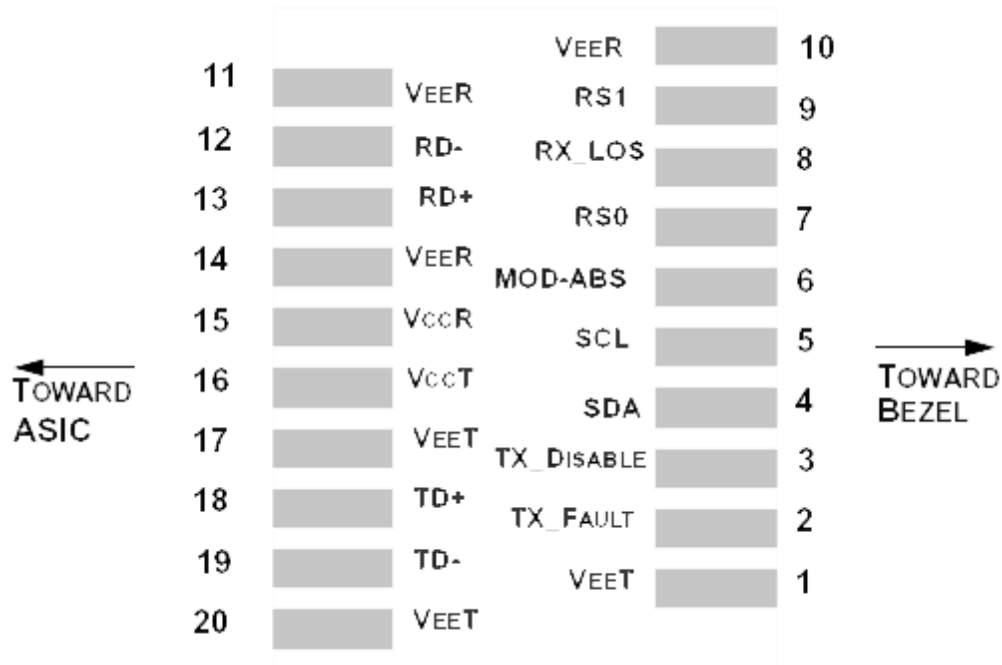

Figure 3,pins view

Table 6-Pin Function Definitions

Pin	Name	FUNCTION	Plug Seq.	Notes
1	VeeT	Transmitter Ground	1	Note 5
2	TX Fault	Transmitter Fault Indication	3	Note 1
3	TX Disable	Transmitter Disable	3	Note 2, Module disables on high or open
4	SDA	Module Definition 2	3	2-wire Serial Interface Data Line.
5	SCL	Module Definition 1	3	2-wire Serial Interface Clock.
6	MOD_ABS	Module Definition 0	3	Note 3
7	RS0	RX Rate Select (LVTTTL).	3	Rate Select 0, optionally controls SFP+ module receiver. This pin is pulled low to VeeT with a >30K resistor..
8	LOS	Loss of Signal	3	Note 4
9	RS1	TX Rate Select (LVTTTL).	1	Rate Select 1, optionally controls SFP+ module transmitter. This pin is pulled low to VeeT with a >30K resistor.
10	VeeR	Receiver Ground	1	Note 5
11	VeeR	Receiver Ground	1	Note 5
12	RD-	Inv. Received Data Out	3	Note 6
13	RD+	Received Data Out	3	Note 6
14	VeeR	Receiver Ground	1	Note 5
15	VccR	Receiver Power	2	3.3 ± 5%, Note 7
16	VccT	Transmitter Power	2	3.3 ± 5%, Note 7
17	VeeT	Transmitter Ground	1	Note 5

18	TD+	Transmit Data In	3	Note 8
19	TD-	Inv. Transmit Data In	3	Note 8
20	VeeT	Transmitter Ground	1	Note 5

Note:

1. TX Fault is an open collector/drain output, which should be pulled up with a 4.7K – 10KΩ resistor on the host board. Pull up voltage between 2.0V and $V_{ccT}/R+0.3V$. When high, output indicates a laser fault of some kind. Low indicates normal operation. In the low state, the output will be pulled to < 0.8V.
2. TX disable is an input that is used to shut down the transmitter optical output. It is pulled up within the module with a 4.7K – 10 KΩ resistor. Its states are: Low (0 – 0.8V): Transmitter on (>0.8, < 2.0V): Undefined High (2.0 – 3.465V): Transmitter Disabled Open: Transmitter Disabled
3. Module Absent, connected to VeeT or VeeR in the module.
4. LOS (Loss of Signal) is an open collector/drain output, which should be pulled up with a 4.7K – 10KΩ resistor. Pull up voltage between 2.0V and $V_{ccT}/R+0.3V$. When high, this output indicates the received optical power is below the worst-case receiver sensitivity (as defined by the standard in use). Low indicates normal operation. In the low state, the output will be pulled to < 0.8V.
5. The module signal ground contacts, VeeR and VeeT, should be isolated from the module case.
6. RD-/+: These are the differential receiver outputs. They are AC coupled 100Ω differential lines which should be terminated with 100Ω (differential) at the user SERDES. The AC coupling is done inside the module and is thus not required on the host board. The voltage swing on these lines will be between 350 and 700 mV differential (175 –350 mV single ended) when properly terminated.
7. VccR and VccT are the receiver and transmitter power supplies. They are defined as 3.3V ±5% at the SFP+ connector pin. Maximum supply current is 725mA. Recommended host board power supply filtering is shown below. Inductors with DC resistance of less than 1 ohm should be used in order to maintain the required voltage at the SFP+ input pin with 3.3V supply voltage. When the recommended supply-filtering network is used, hot plugging of the SFP+ transceiver module will result in an inrush current of no more than 30mA greater than the steady state value. VccR and VccT may be internally connected within the SFP+ transceiver module.
8. TD-/+: These are the differential transmitter inputs. They are AC-coupled, differential lines with 100Ω differential termination inside the module. The AC coupling is done inside the module and is thus not required on the host board. The inputs will accept differential swings of 150 – 1200 mV (75 – 600mV single-ended).

Mechanical Dimension

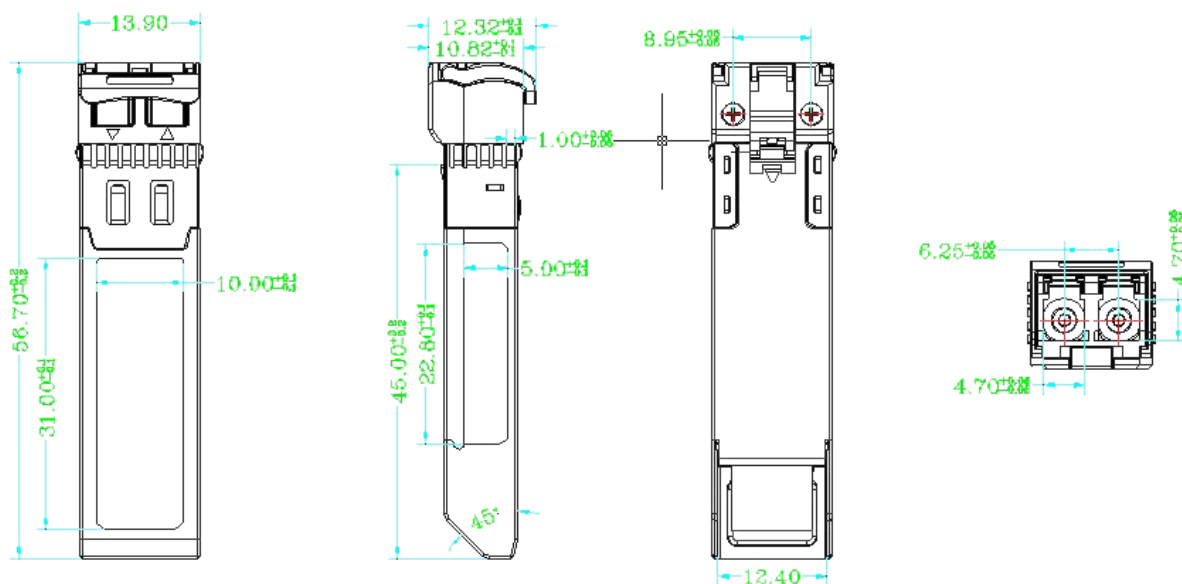

Figure 4,mechanical dimension

Order Information

Table 7-Order Information

Part Number	Product Description
SFP+CWDM	SFP+CWDM EML,0°C~70°C,40Km

Wavelength Guide (** value)

Table 8-wavelength guide

Band	Nomenclature“xx”		Wavelength(nm)		
	duplet	BiDi	Min.	Typ.	Max.
O-band Original	27	A	1264	1270	1277.5
	29	B	1294	1290	1297.5
	31	C	1304	1310	1317.5
	33	D	1324	1330	1337.5
	35	E	1344	1350	1357.5
E-band Extended	37	F	1364	1370	1377.5
	39	G	1384	1390	1397.5
	41	H	1404	1410	1417.5
	43	I	1324	1430	1437.5
	45	J	1444	1450	1457.5
S-band Wavelength Short	47	K	1464	1470	1477.5
	49	L	1484	1490	1497.5
	51	M	1504	1510	1517.5
	53	N	1524	1530	1537.5
C-band Conventional	55	O	1544	1550	1557.5
L-band Long Wavelength	57	P	1564	1570	1577.5
	59	Q	1584	1590	1597.5
	61	R	1604	1610	1617.5

Notice

DYSFO reserves the right to make changes to or discontinue any optical link product or service identified in this publication, without notice, in order to improve design and/or performance. Applications that are described herein for any of the optical link products are for illustrative purposes only. DYSFO makes no representation or warranty that such applications will be suitable for the specified use without further testing or modification.

DYSFO

ShenZhen DYS Fiber optic Technology Co.,Ltd

Tel: 86-0755-29518585, 29650336 Fax : 86-0755-29510505 PC/ZIP: 518133

Add: 2/F, 7 Building, Tangtou Industrial Zone 3rd, Shiyan Town, BaoAn District, Shenzhen, P.R China

