

10G XFP-ER Transceiver

MODEL: XFP-ER



Product Features

- 1550nm EML Transmitter
- Distance up to 40km over SMF
- Single 3.3V Power supply and LVTTTL Logic Interface
- Duplex LC Connector Interface
- Hot Pluggable
- Power Dissipation < 1.5 W
- Dispersion Tolerance 800ps/nm
- Operating Case Temperature
- Standard: 0°C~+70°C
- Compliant with SFF-8431 MSA
- Compliant with SFF-8432 MSA
- Compliant with SFF-8472 MSA

Applications

- 10GBASE-ER/EW
- 8G/10G FC
- Other optical links

Absolute Maximum Ratings

Table 1- Absolute Maximum Ratings

Parameter	Symbol	Min.	Typical	Max.	Unit	Notes
Storage Temperature	Ts	-40	-	85	°C	
Supply Voltage	Vcc5	-0.5	-	4.0	V	
Operating Humidity	RH	-	-	+85	%	

Recommended Operating Conditions

Table 2- Recommended operating Conditions

Parameter	Symbol	Min.	Typ.	Max.	Unit	Notes
Operating Case Temperature	TOP	0		70	°C	
Power Supply Voltage	VCC	3.14	3.3	3.46	V	
Power Supply Current	ICC	-	-	450	mA	
Power Dissipation	PD	-	-	1.5	W	
Data Rate	BR	9.95		11.3	Gbps	

Electrical Characteristics

Table 3- Electrical Characteristics

Transmitter						
Parameter	Symbol	Unit	Min.	Typ.	Max.	Notes
Differential Data Input swing	V _{in,p-p}	mV _{pp}	180	-	700	
Input Differential impedance	Z _{in}	Ω	85	100	115	
Tx_Disable,P_Down/RST	V _{IL}	V	-0.3		0.8	
	V _{IH}	V	2.0	-	V _{cc} +0.3	
Receiver						
Differential Data Output	V _{out}	mV _{pp}	300		850	
Output Differential impedance	Z _{in}	Ω	80	100	120	
Output Rise Time,20%-80%	T _r	Ps	28			
Output Fall Time,20%-80%	T _f	Ps	28			
Rx_Los,Mod_NR,Interrupt	V _{oL}	V	0		0.4	
	V _{oH}	V	V _{cc} -0.5		V _{cc} +0.3	

Transmitter Performance:

Table 4- optical TX Characteristics

Parameter	Symbol	Min.	Typical	Max.	Unit	Notes
Average Launch Optical Power	P _{out}	-4	-	+4	dBm	1
Extinction Ratio	ER	8.2	-	-	dB	2
Average Launch power of OFF TX	P _{off}	-	-	-30	dBm	1
Optical Wavelength	λ	1530	-	1565	nm	
Dispersion penalty@9.95/10.7Gpbs	DP1	-	-	2	dB	2
Dispersion penalty@11.1/11.3Gpbs	DP2	-	-	3	dB	3
Side Mode Suppression Ratio	SMSR	30	-	-	dB	

Receiver Performance:

Table 5- optical RX Characteristics

Parameter	Symbol	Min.	Typical	Max.	Unit	Notes
Receiver Sensitivity @9.95Gpbs/10.7Gpbs	PIN_SENS1	-	-	-16	dBm	2
Receiver Sensitivity @11.1Gpbs/11.3Gpbs	PIN_SENS2	-	-	-14	dBm	3
Overload	PIN_OL	-7.0	-		dBm	3
Optical Center Wavelength	λ _C	1260	-	1600	nm	
LOS	LOSA	-30	-	-	dBm	
	LOSD	-	-	-18	dBm	
Los hysteresis	LOSH	0.5	-		dB	
Rx_LOS	High	2.0		V _{cc} +0.3	V	
	Low	0		0.8	V	

Note:

1. The optical power is launched into SMF.
2. Measured with a PRBS 231-1 test pattern @9.95Gbps.
3. Measured with a PRBS 231-1 test pattern , @11.1Gbps. BER≤10⁻¹².

Recommended Host Board Power Supply Circuit

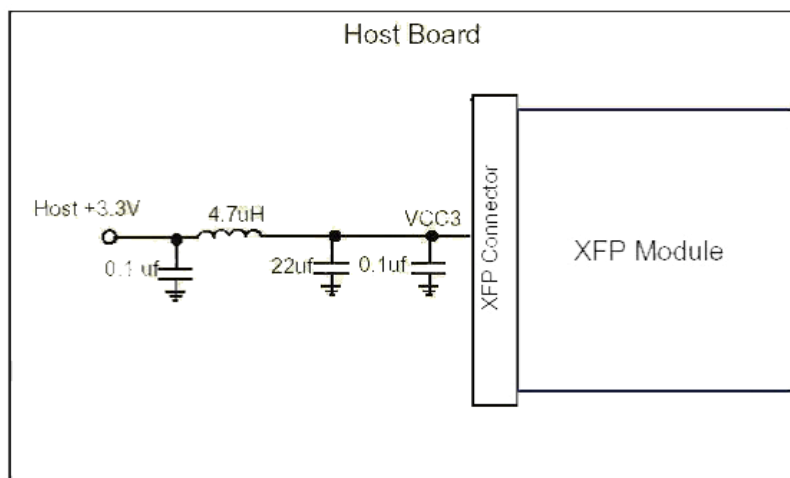

Recommended Interface Circuit

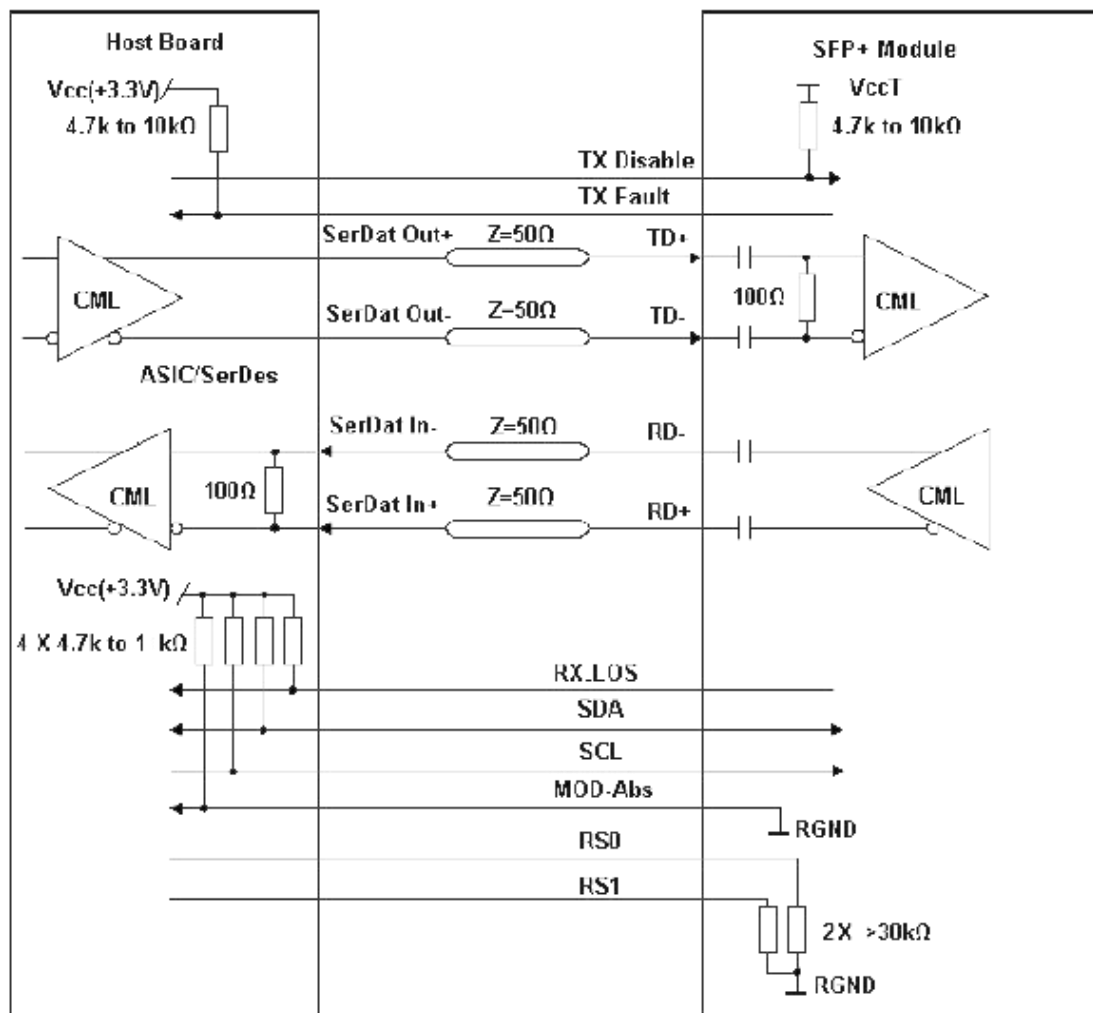

Figure 2, Recommended Interface Circuit

Pin arrangement

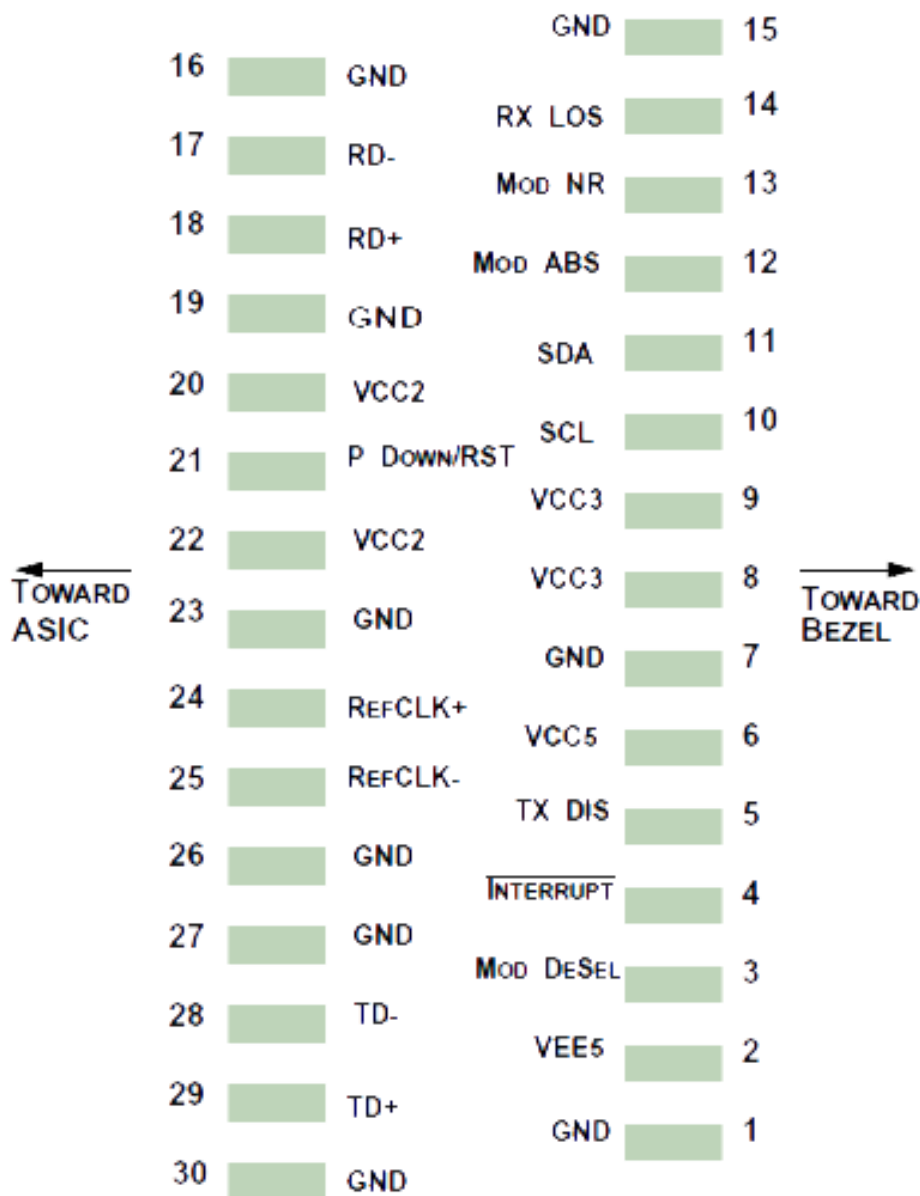

Figure 3, Pin View

Table 6-Pin Function Definitions

Pin	Logic	Symbol	Name/Description	Note
1		GND	Module Ground	1
2		VEE5	Optional -5.2V Power Supply	
3	LVTTTL-I	MOD_DESEL	Module De-select; When held low allows the module to respond to 2-wire serial interface	
4	LVTTTL-O	INTb	Interrupt; Indicates presence of an important	2

			condition which can be read via the 2-wire serial interface	
5	LVTTTL-I	TX_DIS	Transmitter Disable; Turns off transmitter laser output	
6		VCC5	+5V Power Supply	
7		GND	Module Ground	1
8		VCC3	+3.3V Power Supply	
9		VCC3	+3.3V Power Supply	
10	LVTTTL-I/O	SCL	2-Wire Serial Interface Clock	2
11	LVTTTL-I/O	SDA	2-Wire Serial Interface Data Line	2
12	LVTTTL-O	MOD_Abs	Indicates Module is not present. Grounded in the Module	2
13	LVTTTL-O	MOD_NR	Module Not Ready; Indicating Module Operational Fault	2
14	LVTTTL-O	RX_LOS	Receiver Loss Of Signal Indicator	2
15		GND	Module Ground	1
16		GND	Module Ground	1
17	CML-O	RDN	Receiver Inverted Data Output	
18	CML-O	RDP	Receiver Non-Inverted Data Output	
19		GND	Module Ground	1
20		VCC2	+1.8V Power Supply	
21	LVTTTL-I	P_DOWN/RST	Power down; When high, requires the module to limit power consumption to 1.5W or below. 2-Wire serial interface must be functional in the low power mode. Reset; The falling edge initiates a complete reset of the module including the 2-wire serial interface, equivalent to a power cycle.	
22		VCC2	+1.8V Power Supply	
23		GND	Module Ground	1
24	PECL-I	REFCLKP	Not used, internally terminated to 50ohm (100ohm diff).	3
25	PECL-I	REFCLKN	Not used, internally terminated to 50ohm (100ohm diff).	3
26		GND	Module Ground	1
27		GND	Module Ground	1
28	CML-I	TDN	Transmitter Inverted Data Input	
29	CML-I	TDP	Transmitter Non-Inverted Data Input	
30		GND	Module Ground	1

Note:

1. Module circuit ground is isolated from module chassis ground within the module.
2. Open collector; should be pulled up with 4.7k – 10k ohm on host board to a voltage between 3.15V and 3.6V.
3. A Reference Clock input is not required.

Mechanical Dimension:

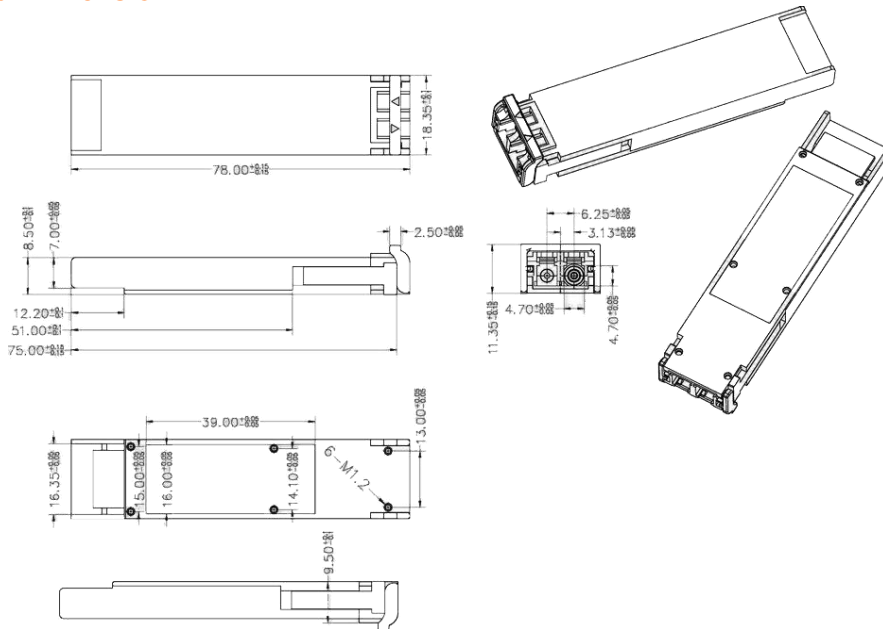

Figure 4, Mechanical Diagram

Order Information

Table 7-Order Information

Part Number	Product Description
XFP-ER	XFP-ER 1550nm EML, 0°C~70°C, 40Km

Notice

DYSFO reserves the right to make changes to or discontinue any optical link product or service identified in this publication, without notice, in order to improve design and/or performance. Applications that are described herein for any of the optical link products are for illustrative purposes only. DYSFO makes no representation or warranty that such applications will be suitable for the specified use without further testing or modification.

DYSFO

ShenZhen DYS Fiber optic Technology Co.,Ltd

Tel: 86-0755-29518585, 29650336 Fax : 86-0755-29510505 PC/ZIP: 518133

Add: 2/F, 7 Building, Tangtou Industrial Zone 3rd, Shiyan Town, BaoAn District, Shenzhen, P.R China

