

GBIC-SX

1.25G 850nm Multi-mode GBIC Transceiver

PRODUCT FEATURES

- Up to 1.25Gb/s data links
- VCSEL laser transmitter and PIN photo-detector
- Up to 550m on 50/125µm MMF
- GBIC footprint
- Duplex SC/UPC type pluggable optical interface
- Low power dissipation
- Metal enclosure, for lower EMI
- RoHS compliant and lead-free
- Single +5V power supply
- Compliant with SFF-8472
- Case operation Temperature: 0°C to +70°C



APPLICATIONS

- Switch to Switch Interface
- Gigabit Ethernet
- Switched Backplane Applications
- Router/Server Interface
- Other Optical Links



PRODUCT DESCRIPTION

ZHT GBIC-SX Small Form Factor Pluggable (SFP) transceivers are compatible with the Small Form Factor Pluggable Multi-Sourcing Agreement (MSA). The transceiver consists of four sections: the LD driver, the limiting amplifier, the VCSEL laser and the PIN photo-detector. The module data link up to 550M in 50/125um multi mode fiber.

The optical output can be disabled by a TTL logic high-level input of Tx Disable, and the system also can disable the module via I2C. Tx Fault is provided to indicate that degradation of the laser. Loss of signal (LOS) output is provided to indicate the loss of an input optical signal of receiver or the link status with partner. The system can also get the LOS (or Link)/Disable/Fault information via I2C register access.

I. Pin Descriptions

Pin	Symbol	I/O Type	Functional Description
1	RX_LOS	Output	Receiver Loss of Signal, Logic high, Open collector compatible 4.7K to 10K Ohm pulls up to VDDT on host.
2	RGND		Receiver Ground
3	RGND		Receiver Ground
4	MOD_DEF(0)	Output	Module Definition 0 TTL Low
5	MOD_DEF(1)	Input	Module Definition 1 Two wire serial ID interface SCL, 4.7K to 10K Ohm pull up to VDDT on host
6	MOD_DEF(2)	I/O	Module Definition 2 Two wire serial ID interface SDA, 4.7K to 10K Ohm pull up to VDDT on host
7	TX_DISABLE	Input	Transmitter Disable – Module disable on high or open (No Used)
8	TGND		Transmitter Ground
9	TGND		Transmitter Ground
10	TX_FAULT	Output	Transmitter Fault Indication, Logic high, open collector Compatible, 4.7K to 10K Ohm pull up to VDDT on host
11	RGND		Receiver Ground
12	-RX_DAT	Output	Inverse Received Data Out, Differential PECL, at AC couple
13	+RX_DAT	Output	Received Data Out, Differential PECL, at AC couple
14	RGND		Receiver Ground
15	VDDR	Input	Receiver Power
16	VDDT	Input	Transmitter Power
17	TGND		Transmitter Ground
18	+TX_DAT	Input	Transmitter Data In, Differential PECL, AC couple
19	-TX_DAT	Input	Inverse Transmitter Data In, Differential PECL, AC couple
20	TGND		Transmitter Ground

II. Absolute Maximum Ratings

Parameter	Symbol	Min.	Typ.	Max.	Unit	Note
Storage Temperature	Ts	-40		85	°C	
Storage Ambient Humidity	HA	5		95	%	
Power Supply Voltage	VCC	0		6	V	
Signal Input Voltage		0		Vcc	V	
Receiver Damage Threshold		5			dBm	

III. Recommended Operating Conditions

Parameter	Symbol	Min.	Typ.	Max.	Unit	Note
Case Operating Temperature	Tcase	0		70	°C	
Ambient Humidity	HA	5		70	%	Non-condensing
Power Supply Voltage	VCC	4.75	5	5.25	V	
Power Supply Current	ICC			300	mA	
Power Supply Noise Rejection				100	mVp-p	100Hz to 1MHz
Data Rate			1250/1250		Mbps	TX Rate/RX Rate
Transmission Distance				550	m	
Coupled Fiber	Multi mode fiber					50/125um MMF

IV. Specification of Transmitter

Parameter	Symbol	Min.	Typ.	Max.	Unit	Note
Average Output Power	POUT	-9		-3	dBm	
Extinction Ratio	ER	9			dB	
Center Wavelength	λ_C	830	850	860	nm	VCSEL Laser
Spectrum width(RMS)	σ			1	nm	
Transmitter OFF Output Power	POff			-45	dBm	
Differential Line Input Impedance	RIN	90	100	110	Ohm	
Jitter P-P	Jp-p			0.1	UI	Note (1)
Output Eye Mask	Compliant with IEEE802.3 z (class 1 laser safety)					Note (2)

Note (1): Measure at 2⁷-1 NRZ PRBS pattern.

Note (2): Transmitter eye mask definition.

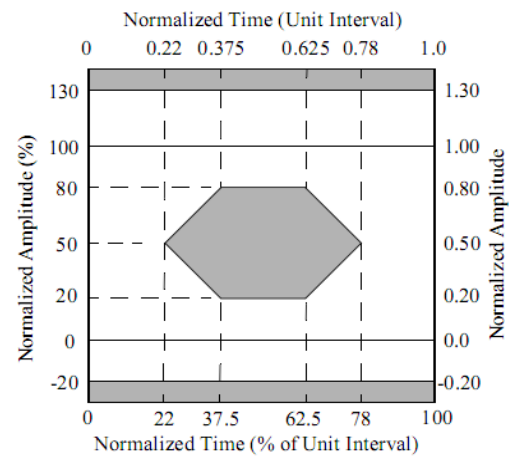

V. Specification of Receiver

Parameter	Symbol	Min.	Typ.	Max.	Unit	Note
Input Optical Wavelength	λ_{IN}	770	850	860	nm	PIN-TIA
Receiver Sensitivity	PIN			-18	dBm	Note (1)
Input Saturation Power (Overload)	PSAT	0			dBm	
Los Of Signal Assert	PA	-38			dBm	
Los Of Signal De-assert	PD			-20	dBm	Note (2)
LOS Hysteresis	PA-PD	0.5	2	6	dB	

Note (1): Measured with Light source 850nm, ER=9dB; BER $\leq 10^{-12}$ @PRBS=2⁷-1 NRZ.

Note (2): When LOS de-asserted, the RX data+/- output is signal output.

VI. Electrical Interface Characteristics

Parameter	Symbol	Min.	Typ.	Max.	Unit	Note
Transmitter						
Total Supply Current	ICC			A	mA	Note (1)
Transmitter Disable Input-High	VDISH	2		V _{cc} +0.3	V	
Transmitter Disable Input-Low	VDISL	0		0.8	V	
Transmitter Fault Input-High	VDISL	2		V _{cc} +0.3	V	
Transmitter Fault Input-Low	VTxFH	0		0.8	V	
Receiver						
Total Supply Current	ICC			B	mA	Note (1)
LOSS Output Voltage-High	VLOSH	2		V _{cc} +0.3	V	LVTTTL
LOSS Output Voltage-Low	VLOSL	0		0.8	V	

Note (1): A (TX) + B (RX) = 300mA (Not include termination circuit)

VII. Mechanical Specifications (Unit: mm)

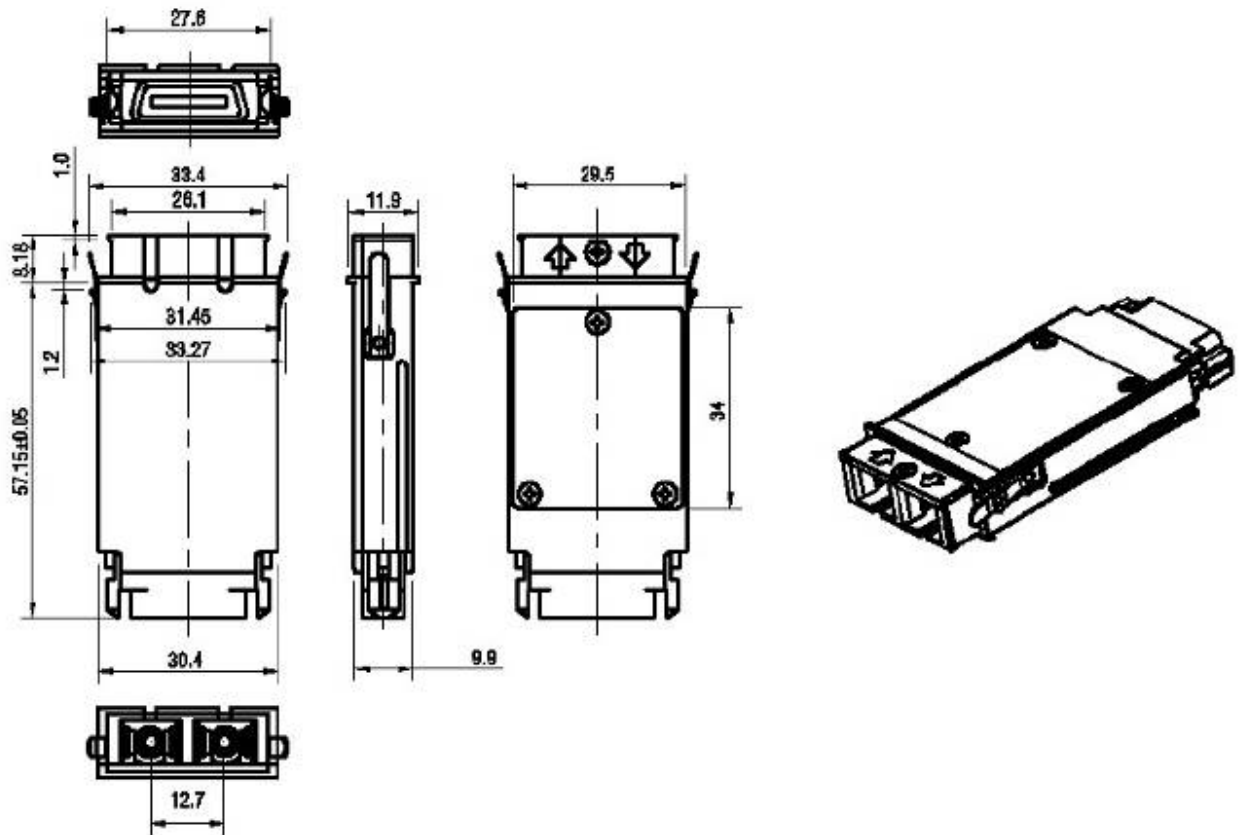

GBIC-SX

Appendix A. Document Revision

Version No.	Date	Description
1.0	2011-10-26	Preliminary datasheet