

155M LC Duplex SFP Transceiver

MODEL: SFP-LH-120



Feature:

- 125M 100BASE application
- 155M OC3 application/SDH/SONET
- 1310nm FP laser and PIN photo detector for 2KM, 20KM and 40KM transmission
- 1550nm uncooled DFB laser and pin photo detector for 80KM
- SFP MSA package with duplex LC connector
- +3.3V single power supply
- Power consumption less than 1W
- Operating case temp
- Standard temp: 0~+70°C
- Industrial temp:-40~+85°C
- Compliant with RoHS

Absolute Maximum Ratings

Table 1- Absolute Maximum Ratings

| | Symbol | Min. | Typical | Max. | Unit | Notes |
|---------------------|--------|------|---------|------|------|-------|
| Supply Voltage | Vcc3 | -0.5 | - | +3.6 | V | |
| Storage Temperature | Ts | -40 | - | 85 | °C | |
| Operating Humidity | RH | +5 | - | +95 | % | |

Recommended Operating Conditions

Table 2- Recommended operating Conditions

| Parameter | | Symbol | Min. | Typical | Max. | Unit | Notes |
|----------------------|------------|--------|------|---------|------|------|-------|
| Operating | Standard | TC | 0 | - | +70 | °C | |
| Case Temperature | Industrial | | -40 | - | +85 | °C | |
| Power Supply Voltage | | Vcc | 3.13 | 3.3 | 3.47 | V | |
| Power Supply Current | | Icc | - | - | 300 | mA | |
| Power Dissipation | | Pd | - | - | 1 | W | |

| | | | | | | |
|-----------|--|---|-----|---|------|--|
| Data Rate | | - | 155 | - | Mbps | |
|-----------|--|---|-----|---|------|--|

Electrical Characteristics

Table 3- Electrical Characteristics

| Parameter | Symbol | Unit | Min. | Typ. | Max. | Notes |
|-----------------------------------|--------|----------|------|-------|------|-------|
| Electrical Characteristics | | | | | | |
| Supply Current | ICC | mA | - | - | 300 | |
| Differential Data Input Swing | | mV | 200 | - | 2400 | 1 |
| Differential Data Output Swing | | mV | 1450 | 1600- | 1750 | 2 |
| Differential Data input impedance | | Ω | - | 100 | - | 1 |
| Signal Level(LVTTL H) | | V | 2.4 | - | VCC | |
| Signal Level(LVTTL L) | | V | 0 | - | 0.8 | |

Note:

1. Internally AC coupled, input termination may be required for CML or LVPECL applications.
2. Internally AC coupled, CML differential output stage.

Optical Characteristics

Table 4-Optical Characteristics

SFP-LH-120 (1310nm FP and PIN, 20KM, NO DDMI)

SFP-LH-120D (1310nm FP and PIN, 20KM, DDMI)

| Parameter | Symbol | Unit | Min. | Typ. | Max. | Notes |
|-------------------------------------|--|------|------|------|------|-------|
| Optical transmitter Characteristics | | | | | | |
| Data Rate | | Mbps | - | 155 | - | |
| Center Wavelength Range | λ_C | nm | 1290 | 1310 | 1330 | |
| Spectral Width(@-20dB) | $\Delta\lambda$ | nm | - | - | 7.7 | |
| Launch Optical Power | P0 | dBm | -14 | - | -5 | 1 |
| Extinction Ratio | ER | dB | 9 | - | - | |
| Jitter Generation(pK-pK) | | UI | - | - | 0.1 | |
| Jitter Generation(RMS) | | UI | - | - | 0.01 | |
| Eye Diagram | Compliant with Telcordia GR-253-CORE and ITU-T G.957 | | | | | |
| Optical receive Characteristics | | | | | | |
| Data Rate | | Mbps | - | 155 | - | |
| Receiver Sensitivity | | dBm | - | - | -32 | |
| Overload Input Optical Power | PIN | dBm | -8 | - | - | |
| Center Wavelength Range | λ_c | nm | 1290 | 1310 | 1330 | |
| LOS | LOSA | dBm | -43 | - | - | |
| | LOSD | | - | - | -33 | |
| LOS Hysteresis | | dB | 0.5 | - | - | |

Note:

Coupled into 9/125 SMF.

Recommended Interface Circuit

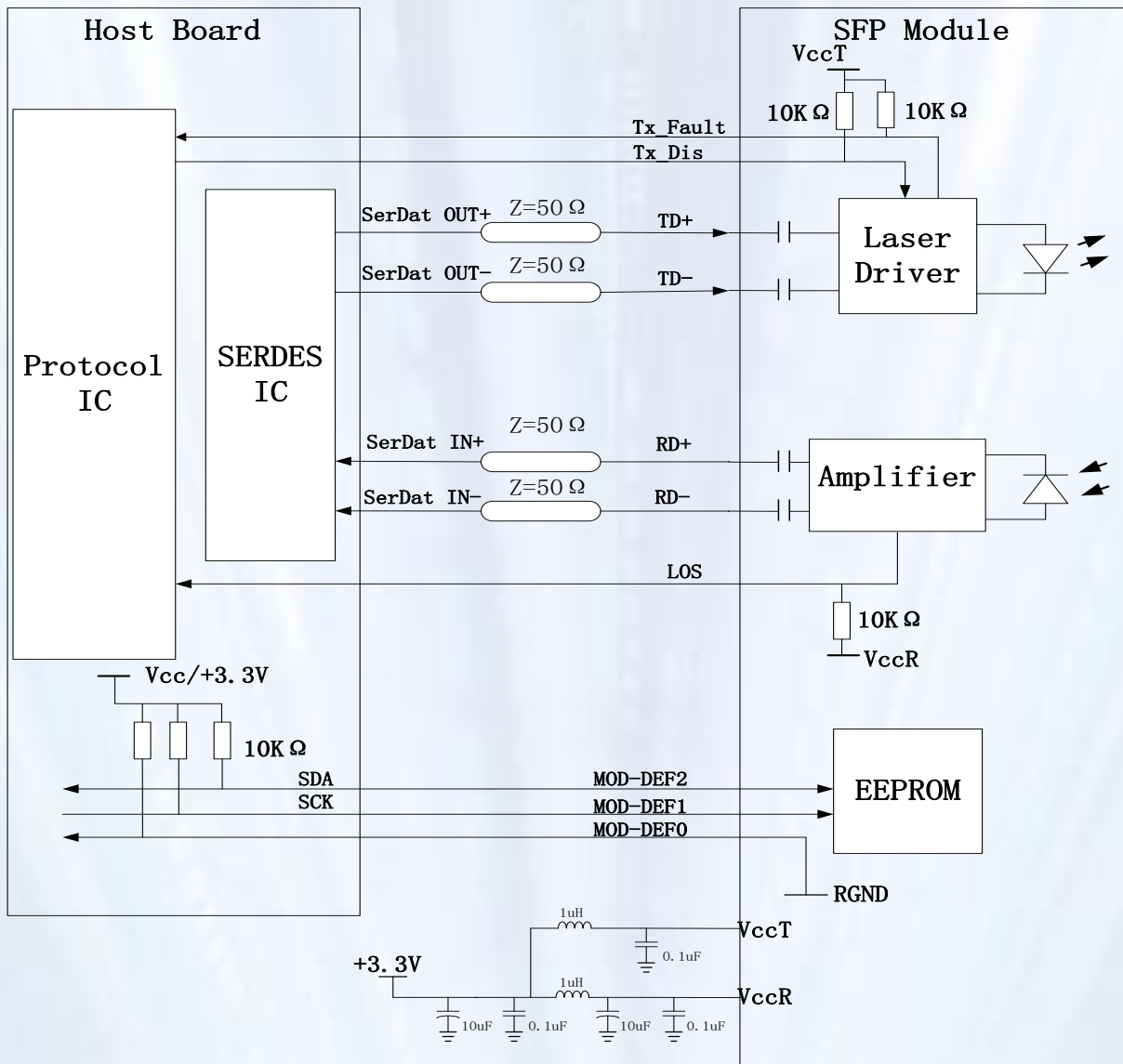

Figure 1, Recommended Interface Circuit

Recommended Host Board Power Supply Circuit

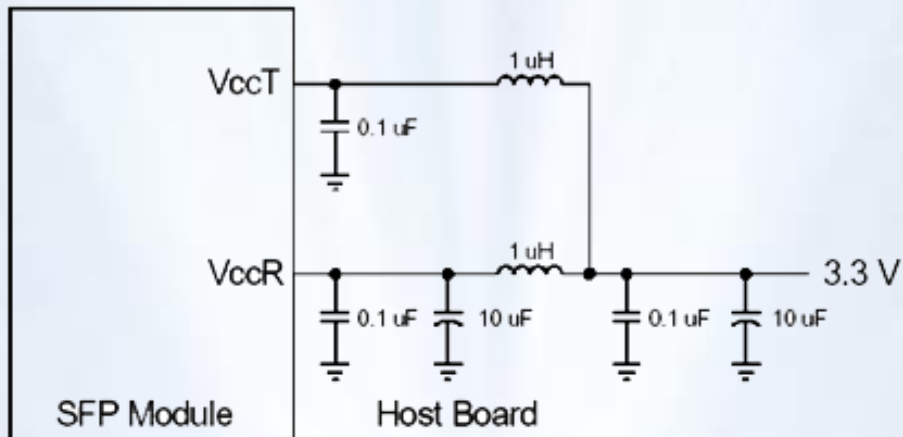

Figure 2, Recommended Host Board Power Supply Circuit

Pin arrangement

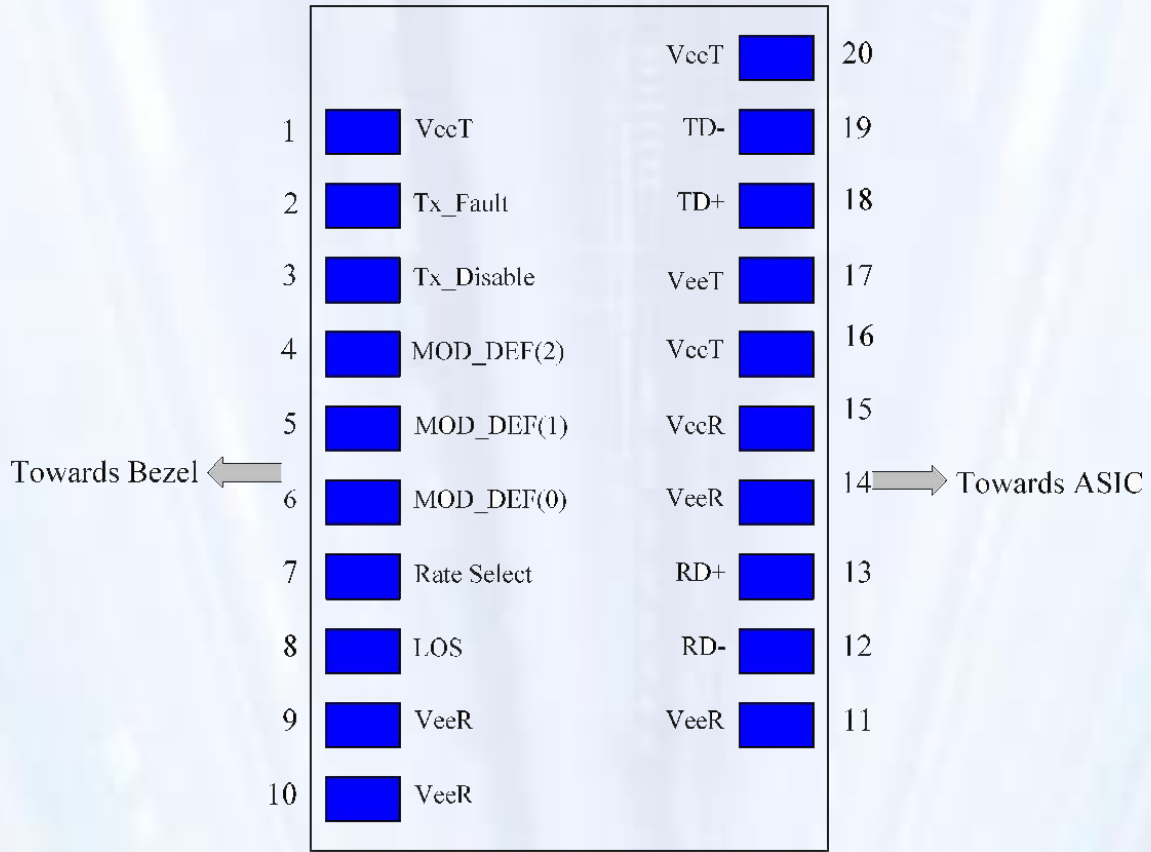

Figure 3, Pin View

Table 8-Pin Function Definitions

| Pin | Name | FUNCTION | Plug Seq. | Notes |
|-----|-------------|------------------------------|-----------|---|
| 1 | VeeT | Transmitter Ground | 1 | |
| 2 | TX Fault | Transmitter Fault Indication | 3 | Note 1 |
| 3 | TX Disable | Transmitter Disable | 3 | Note 2, Module disables on high or open |
| 4 | MOD-DEF2 | Module Definition 2 | 3 | Note 3, Data line for Serial ID. |
| 5 | MOD-DEF1 | Module Definition 1 | 3 | Note 3, Clock line for Serial ID. |
| 6 | MOD-DEF0 | Module Definition 0 | 3 | Note 3, Grounded within the module. |
| 7 | Rate Select | Not Connect | 3 | Function not available |
| 8 | LOS | Loss of Signal | 3 | Note 4 |
| 9 | VeeR | Receiver Ground | 1 | Note 5 |
| 10 | VeeR | Receiver Ground | 1 | Note 5 |
| 11 | VeeR | Receiver Ground | 1 | Note 5 |
| 12 | RD- | Inv. Received Data Out | 3 | Note 6 |
| 13 | RD+ | Received Data Out | 3 | |
| 14 | VeeR | Receiver Ground | 1 | Note 5 |
| 15 | VccR | Receiver Power | 2 | 3.3 ± 5% |
| 16 | VccT | Transmitter Power | 2 | 3.3 ± 5% |
| 17 | VeeT | Transmitter Ground | 1 | Note 5 |
| 18 | TD+ | Transmit Data In | 3 | |
| 19 | TD- | Inv. Transmit Data In | 3 | |
| 20 | VeeT | Transmitter Ground | 1 | Note 5 |

Note:

- TX Fault is open collector output which should be pulled up externally with a 4.7K ~10KΩ resistor on the host board to voltage between 2.0V and VCC+0.3V. Logic 0 indicates normal operation; logic 1 indicates a laser fault of some kind. In the low state, the output will be pulled to less than 0.8V.
- TX Disable input is used to shut down the laser output per the state table below. It is pulled up within the module with a 4.7~ 10K resistor.

| | |
|------------------------|----------------------|
| Low (0- 0.8V): | Transmitter on |
| Between (0.8V and 2V): | Undefined |
| High (2.0 – VccT): | Transmitter Disabled |
- MOD-DEF 0, 1, 2. These are the module definition pins. They should be pulled up with a 4.7~10K resistor on the host board to supply less than VccT+0.3V or VccR+0.3V.
 MOD-DEF 0 is grounded by the module to indicate that the module is present.
 MOD-DEF 1 is clock line of two wire serial interface for optional serial ID.
 MOD-DEF 2 is data line of two wire serial interface for optional serial ID.
- LOS (Loss of signal) is an open collector output, which should be pulled up with a 4.7k~10kΩ resistor on the host board to a voltage between 2.0V and Vcc+0.3V. Logic 0 indicates normal operation; logic 1 indicates loss of signal. In the low state, the output will be pulled to less than 0.8V.
- These are the differential receiver outputs. They are AC-coupled 100Ω differential lines which should be terminated with 100Ω differential at the user SERDES. The AC coupling is done inside the module and thus not required on the host board.
- These are the differential transmitter inputs. They are AC-coupled, differential lines with 100Ω differential termination inside the module.

Digital Diagnostic Memory Map

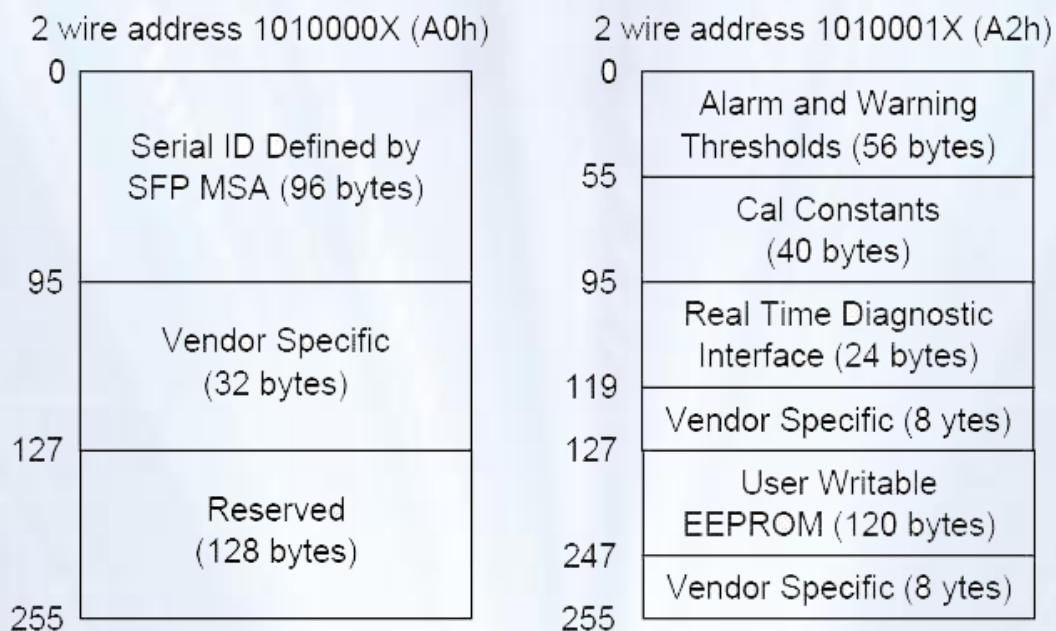

Figure 4, memory map

Mechanical Diagram

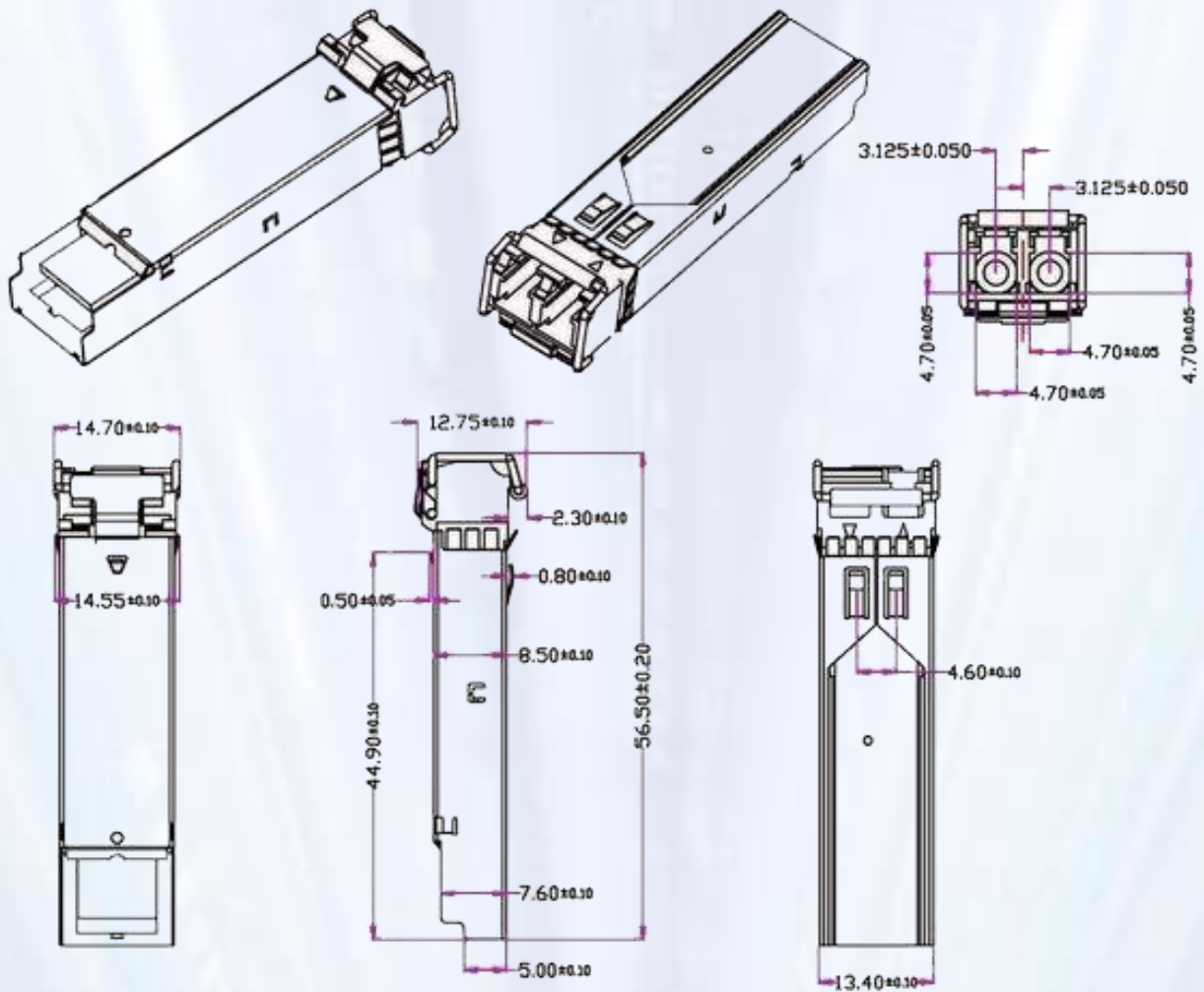

Figure 5, mechanical diagram

Order Information

Table9-order information

| Part Number | Product Description |
|--------------|---|
| SFP-LH-120 | SFP 1310nm, 155M, 20KM, NO DDM ,0°C~70°C |
| SFP-LH-120I | SFP 1310nm, 155M, 20KM, NO DDM , -40°C~85°C |
| SFP-LH-120D | SFP 1310nm, 155M, 20KM, DDM ,0°C~70°C |
| SFP-LH-120LD | SFP 1310nm, 155M, 20KM, DDM , -40°C~85°C |

Notice

ZHT reserves the right to make changes to or discontinue any optical link product or service identified in this publication, without notice, in order to improve design and/or performance. Applications that are described herein for any of the optical link products are for illustrative purposes only. ZHT makes no representation or warranty that such applications will be suitable for the specified use without further testing or modification.

Due to continuous improvement, all products specifications are subject to change without further notice. Contact us for custom requirements. E-mail: Sales@zhtelecomm.com Website: www.zhtelecomm.com Tel: +86-01081593787 Fax: +86-01081593789