

155M ~ 2.5G Multi Rate SFP

Model: SFP-MR-1550-40



Features:

- SDH STM- 16 and SONET OC - 48 system
- Data rate up to 2.5G
- 1310nm FP laser and PIN photo detector for 2KM and DFB laser and PIN photo detector for 15KM transmission 1550nm uncooled DFB laser and pin photo detector for 40KM and 80KM
- SFP MSA package with duplex LC connector
- +3.3V single power supply
- Power consumption less than 1W
- Operating case temp
- Standard temp: 0~+70°C
- Industrial temp:-40~+85°C
- Compliant with SFP MSA

Absolute Maximum Ratings

Table 1- Absolute Maximum Ratings

Parameter	Symbol	Min.	Typical	Max.	Unit	Notes
Supply Voltage	Vcc3	-0.5	-	+3.6	V	
Storage Temperature	Ts	-40	-	85	°C	
Operating Humidity	RH	+5	-	+95	%	

Recommended Operating Conditions

Table 2- Recommended operating Conditions

Parameter		Symbol	Min.	Typical	Max.	Unit	Notes
Operating	Standard	TC	0	-	+70	°C	
Case Temperature	Industrial		-40	-	+85	°C	
Power Supply Voltage		Vcc	3.13	3.3	3.47	V	
Power Supply Current		Icc	-	-	300	mA	
Power Dissipation		Pd	-	-	1	W	
Data Rate			-	2488	-	Mbps	

Electrical Characteristics

Table 3- Electrical Characteristics

Parameter	Symbol	Unit	Min.	Typ.	Max.	Notes
Electrical Characteristics						
Supply Current	ICC	mA	-	-	300	

Differential Data Input Swing		mV	200	-	2400	1
Differential Data Output Swing		mV	750	900	1050	2
Differential Data input impedance		Ω	-	100	-	1
Signal Level(LVTTL H)		V	2.4	-	VCC	
Signal Level(LVTTL L)		V	0	-	0.8	

Note:

Internally AC coupled, input termination may be required for CML or LVPECL applications.
Internally AC coupled, CML differential output stage.

Optical Characteristics

Table 4-Optical Characteristics

SFP-MR-1510-40 (1550nm DFB and PIN,40KM,NO DDMI)

SFP-MR-1510-40D(1550nm DFB and PIN,40KM, DDMI)

Parameter	Symbol	Unit	Min.	Typ.	Max.	Notes
Optical transmitter Characteristics						
Data Rate		Mbps	-	2488	-	
Center Wavelength Range	λ_C	nm	1530	1550	1570	
Launch Optical Power	P0	dBm	-5	-	0	1
Extinction Ratio	ER	dB	8.2	-	-	
Jitter Generation(pK-pK)		UI	-	-	0.1	
Jitter Generation(RMS)		UI	-	-	0.01	
Eye Diagram	Complies with STM - 16 eye masks when filtered					
Optical receive Characteristics						
Data Rate		Mbps	-	2488	-	
Receiver Sensitivity		dBm	-	-	-20	
Overload Input Optical Power	PIN	dBm	0	-	-	
Center Wavelength Range	λ_c	nm	1530	1550	1570	
LOS	LOSA	dBm	-31	-	-	
	LOSD		-	-	-21	
LOS Hysteresis		dB	0.5	-	-	

Note:

Coupled into 9/125 SMF.

Recommended Interface Circuit

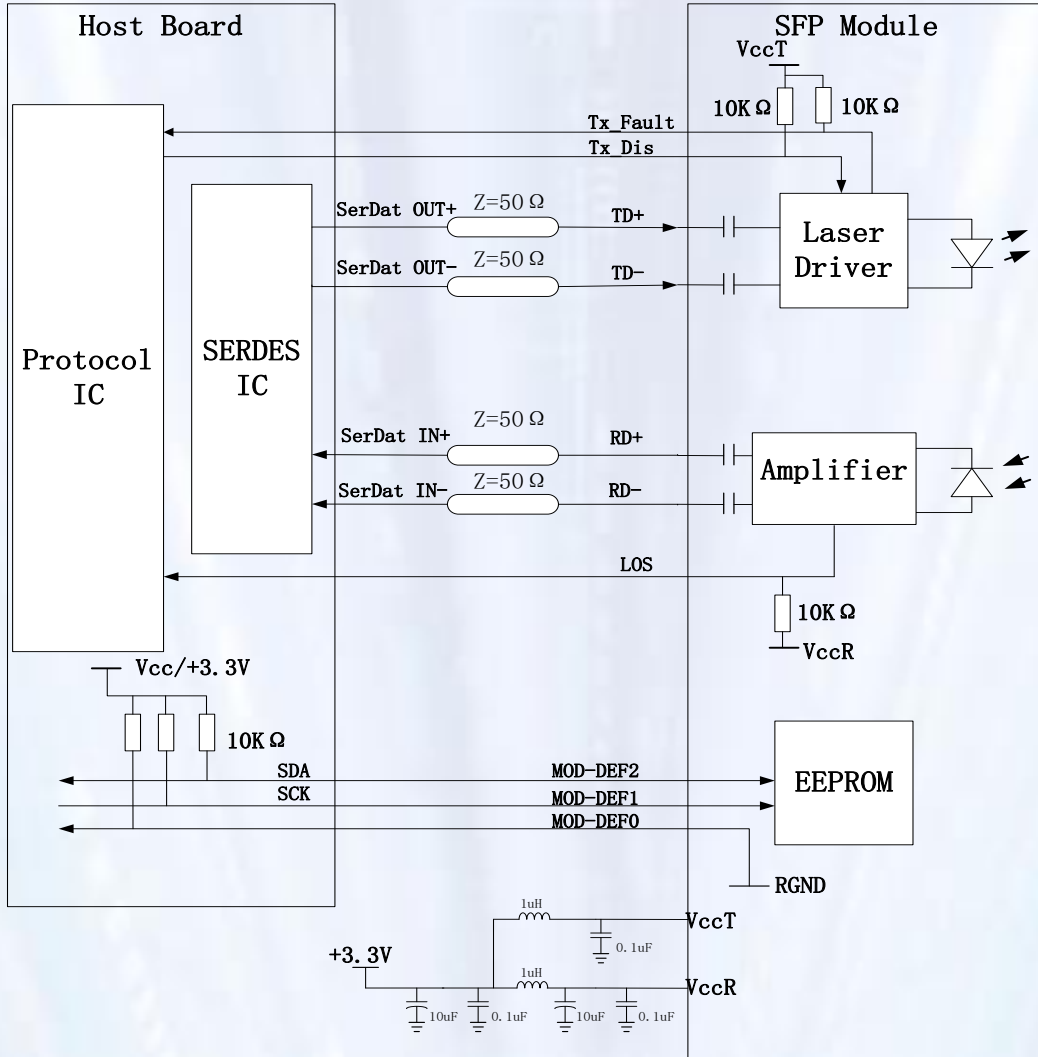

Figure 1, Recommended Interface Circuit

Recommended Host Board Power Supply Circuit

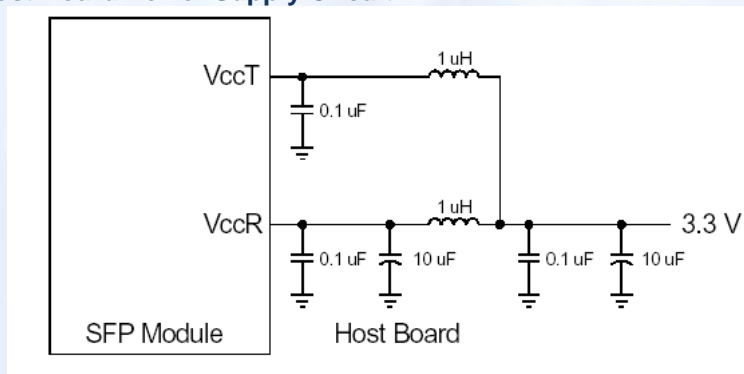

Figure 2, Recommended Host Board Power Supply Circuit

Pin arrangement

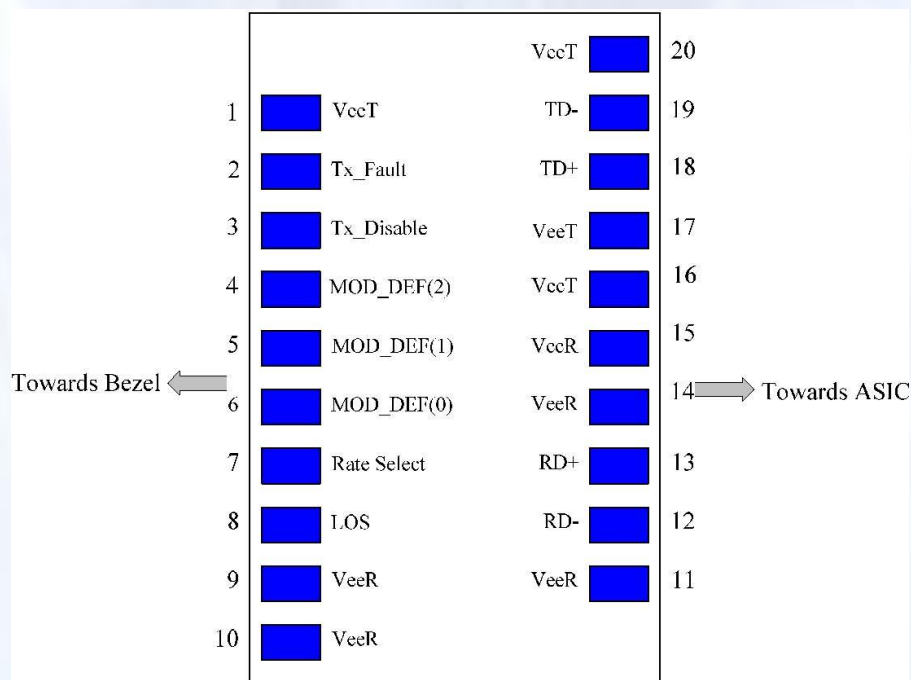

Figure 3, Pin View

Table 5-Pin Function Definitions

Pin	Name	FUNCTION	Plug Seq.	Notes
1	VeeT	Transmitter Ground	1	
2	TX Fault	Transmitter Fault Indication	3	Note 1
3	TX Disable	Transmitter Disable	3	Note 2, Module disables on high or open
4	MOD-DEF2	Module Definition 2	3	Note 3, Data line for Serial ID.
5	MOD-DEF1	Module Definition 1	3	Note 3, Clock line for Serial ID.
6	MOD-DEF0	Module Definition 0	3	Note 3, Grounded within the module.
7	Rate Select	Not Connect	3	Function not available
8	LOS	Loss of Signal	3	Note 4
9	VeeR	Receiver Ground	1	Note 5
10	VeeR	Receiver Ground	1	Note 5
11	VeeR	Receiver Ground	1	Note 5
12	RD-	Inv. Received Data Out	3	Note 6
13	RD+	Received Data Out	3	
14	VeeR	Receiver Ground	1	Note 5
15	VccR	Receiver Power	2	3.3 ± 5%
16	VccT	Transmitter Power	2	3.3 ± 5%
17	VeeT	Transmitter Ground	1	Note 5
18	TD+	Transmit Data In	3	

19	TD-	Inv. Transmit Data In	3	
20	VeeT	Transmitter Ground	1	Note 5

Note:

TX Fault is open collector output which should be pulled up externally with a 4.7K ~10KΩ resistor on the host board to voltage between 2.0V and VCC+0.3V. Logic 0 indicates normal operation; logic 1 indicates a laser fault of some kind. In the low state, the output will be pulled to less than 0.8V.

TX Disable input is used to shut down the laser output per the state table below. It is pulled up within the module with a 4.7~ 10K resistor.

Low (0- 0.8V):	Transmitter on
Between (0.8V and 2V):	Undefined
High (2.0 – VccT):	Transmitter Disabled
Open:	Transmitter Disabled

MOD-DEF 0, 1, 2. These are the module definition pins. They should be pulled up with a 4.7~10K resistor on the host board to supply less than VccT+0.3V or VccR+0.3V. MOD-DEF 0 is grounded by the module to indicate that the module is present. MOD-DEF 1 is clock line of two wire serial interface for optional serial ID.

MOD-DEF 2 is data line of two wire serial interface for optional serial ID.

LOS (Loss of signal) is an open collector output, which should be pulled up with a 4.7k~10kΩ resistor on the host board to a voltage between 2.0V and Vcc+0.3V. Logic 0 indicates normal operation; logic 1 indicates loss of signal. In the low state, the output will be pulled to less than 0.8V.

These are the differential receiver outputs. They are AC-coupled 100Ω differential lines which should be terminated with 100Ω differential at the user SERDES. The AC coupling is done inside the module and thus not required on the host board.

These are the differential transmitter inputs. They are AC-coupled, differential lines with 100Ω differential termination inside the module.

Digital Diagnostic Memory Map

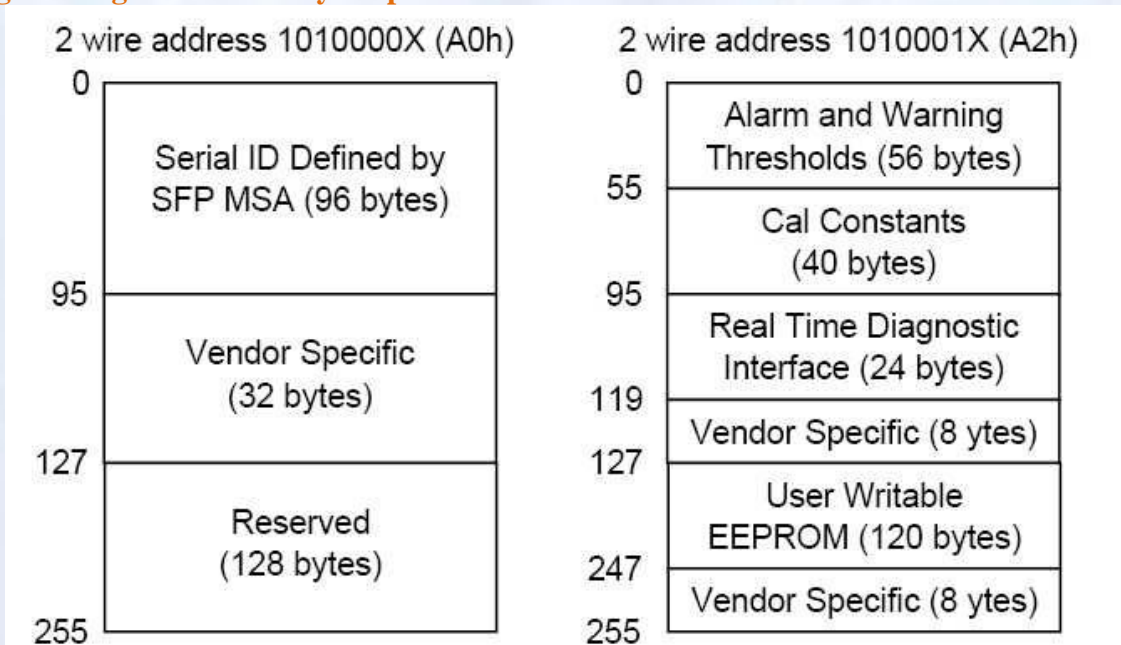

Figure 4, memory map

Mechanical Diagram

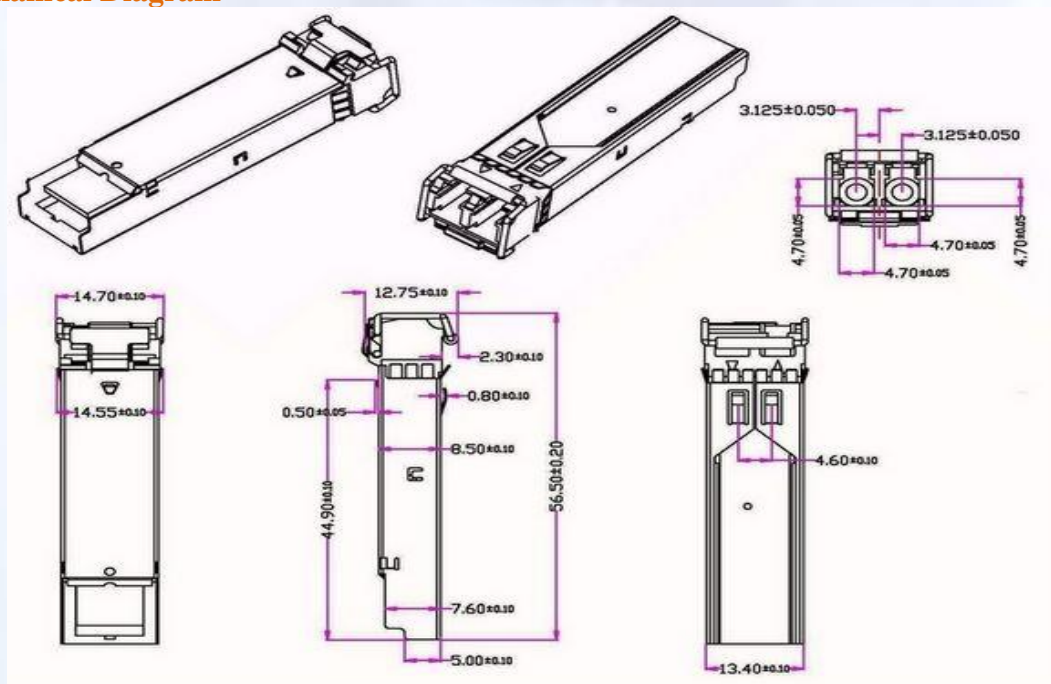

Figure 5, mechanical diagram

Order Information

Table 6-order information

Part Number	Product Description
SFP-MR-1310-2	SFP 1310nm,2.5G, 2KM, NO DDM ,0°C~70°C
SFP-MR-1310-2L	SFP 1310nm,2.5G, 2KM, NO DDM ,-40°C~85°C
SFP-MR-1310-2D	SFP 1310nm,2.5G, 2KM, DDM ,0°C~70°C
SFP-MR-1310-2LD	SFP 1310nm,2.5G, 2KM, DDM ,-40°C~85°C
SFP-MR-1310-15	SFP 1310nm,2.5G, 15KM, NO DDM ,0°C~70°C
SFP-MR-1310-15L	SFP 1310nm,2.5G, 15KM, NO DDM ,-40°C~85°C
SFP-MR-1310-15D	SFP 1310nm,2.5G, 15KM, DDM ,0°C~70°C
SFP-MR-1310-15LD	SFP 1310nm,2.5G, 15KM, DDM ,-40°C~85°C
SFP-MR-1550-40	SFP 1550nm,2.5G, 40KM, NO DDM ,0°C~70°C
SFP-MR-1550-40L	SFP 1550nm,2.5G, 40KM, NO DDM ,-40°C~85°C
SFP-MR-1550-40D	SFP 1550nm,2.5G, 40KM, DDM ,0°C~70°C
SFP-MR-1550-40LD	SFP 1550nm,2.5G, 40KM, DDM ,-40°C~85°C
SFP-MR-850-05	SFP 850nm,2.5G, 550M, NO DDM ,0°C~70°C
SFP-MR-850-05D	SFP 850nm,2.5G, 550M, DDM , 0°C~70°C

Notice

ZHT reserves the right to make changes to or discontinue any optical link product or service identified in this publication, without notice, in order to improve design and/or performance. Applications that are described herein for any of the optical link products are for illustrative purposes only. ZHT makes no representation or warranty that such applications will be suitable for the specified use without further testing or modification.

Due to continuous improvement, all products specifications are subject to change without further notice. Contact us for custom requirements. E-mail: Sales@zhtelecomm.com Website: ww.zhtelecomm.com Tel: +86-01081593787 Fax: +86-01081593789